

RoHS COMPLIANT

DESCRIPTION CONTROL			
REV	DESC	DATE	APP
A	FIRST RELEASE	2013/11/19	
B	CHANGE PIN ASSIGNMENT	2013/12/25	

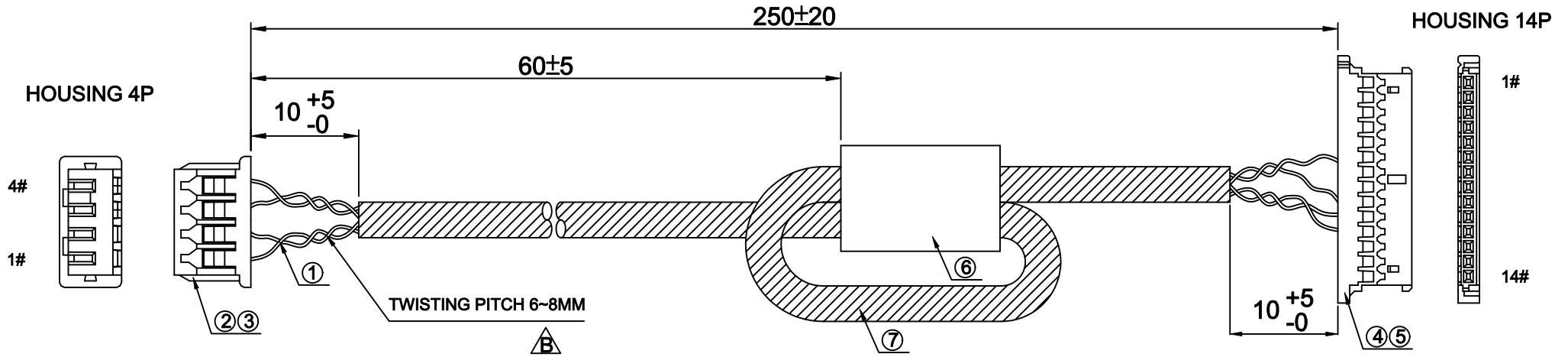

NOTES:

1. PIN ASSIGNMENT SEE TO WIRE LIST.
2. ELECTRICAL TEST CONDITION:
 - (a). 100% OPEN, SHORT & MISWIRE TEST,
 - (b). INSULATOR RESISTANCE: 20 Mohm MIN.
DC 300V 0.01sec,
 - (c). CONTACT RESISTANCE: 1 ohm MAX.

PIN ASSIGNMENT

HOUSING 4P HOUSING 14P

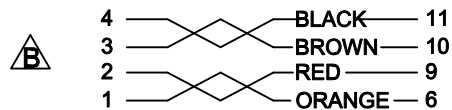

ITEM	QTY	PART NUMBER	DESCRIPTION
7	1	T0024	BLACK HEAT SHRINK TUBE.
6	1		CORE: 7*5.3*9.5MM.
5	4		TERMINAL: PITCH 1.25MM (P/N: 50641-8041).
4	1		HOUSING: PITCH 1.25MM 14PIN (P/N: 51146-1400).
3	4		TERMINAL: PITCH 1.25MM (P/N: 50058-8000).
2	1		HOUSING: PITCH 1.25MM 4PIN (P/N: 51021-0400).
1	4		UL1571 28AWG JUMP WIRE BLACK/BROWN/RED/ORANGE.

UNIT	mm	Projection			Seconn International Enterprise Co., Ltd.
DRAWN	Huang shenggen	SCALE	1:1		
CHECK, BY		REV	B	HOUSING 4P/14P	
APP, BY		DATE	2013/11/19		
DWG NO.	SE-S-0091		X= ±	.X=	
PART NO.	TCBH.685661.004 SB		SHEET	1/1	